

UEI

LED illuminator for Esprit Compact, wavelength available 850nm, 940nm and white light.



Technical data

General

Wavelength: 850nm, 940nm (UEIxxx only), white light

UEIxxx

- Wide beam: 40° (horizontal), 16° (vertical)
- Spot beam: 14° (horizontal), 14° (vertical)

UEIxxxP

- Wide beam: 13° (horizontal), 13° (vertical)
- Spot beam: 13° (horizontal), 13° (vertical)

Wide beam activation: based on the scene brightness, from alarm input or manually

Spot beam activation (can be activated only when the wide beam is active): can be activated on preset, based on the zoom factor or with the wide beam

Automatic and remote switching on

No calibration required for light beam alignment with the camera

The illuminator does not slow down the P&T's rotation speed

Automatic recognition of the type of illuminator installed

Mechanical

Die cast aluminum body

Dimensions (WxHxL): 97×53×54mm (3.8×2×2.1in)

Unit weight: 0.25kg (0.55lb)

Electrical

Power consumption: 13W

Environment

For indoors and outdoors installation

Operating temperature

- Continuous working: from -40°C (-40°F) up to +55°C (131°F)

Certifications

KC certification (UEI8AA, UEI8AAP)

Part number

UEI8AA	850nm IR Illuminator for Esprit Compact with uniform light beam for short and long distances, up to 100m (328ft) with 2MP and 30m (98ft) with 4MP/8MP, colour grey-white (RAL9002)
UEI8AAP	IR Illuminator 850nm for Esprit Compact for long distances, up to 200m (656ft) with 2MP and 75m (246ft) with 4MP/8MP, colour grey-white (RAL9002)
UEI9AA	IR illuminator 940nm for Esprit Compact with uniform lighting for short and long distances, up to 75m (246ft) with 2MP and 20m (66ft) with 4MP/8MP, colour grey-white (RAL9002)
UEIWAA	White light illuminator for Esprit Compact with uniform lighting for short and long distances, up to 150m (492ft) with 2MP and 50m (164ft) with 4MP/8MP, colour grey-white (RAL9002)
UEIWAAP	White light illuminator for Esprit Compact for long distances, up to 200m (656ft) with 2MP and 100m (328ft) with 4MP/8MP, colour grey-white (RAL9002)

Package

Model Number	Weight	Dimensions (WxHxL)	Master carton
UEIxxx	0.4kg (0,9lb)	9.5×13×19.5cm (3.7×5×7.7in)	-

Technical drawings

The indicated measurements are expressed in millimetres.

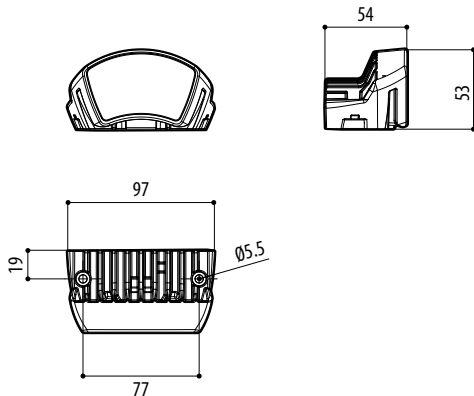

UEI

Support

Learn more and find additional documentation at pelco.com or email support@pelco.com for specific product support.

© 2025, Pelco Inc. All rights reserved. MOTOROLA, MOTO, MOTOROLA SOLUTIONS, and the Stylized M Logo are trademarks or registered trademarks of Motorola Trademark Holdings, LLC and are used under license. Pelco, the Pelco logo, and other trademarks associated with Pelco products referred to in this publication are trademarks of Pelco, Inc. or its affiliates. All other product names and services are the property of their respective companies. Product specifications and availability are subject to change without notice.

SEP 2025 | | REV 3

PELCO